

**ZX0130**

**BREVETTATO  
PATENTED**

F/F/F tee.

## Technical specifications

### Drawing

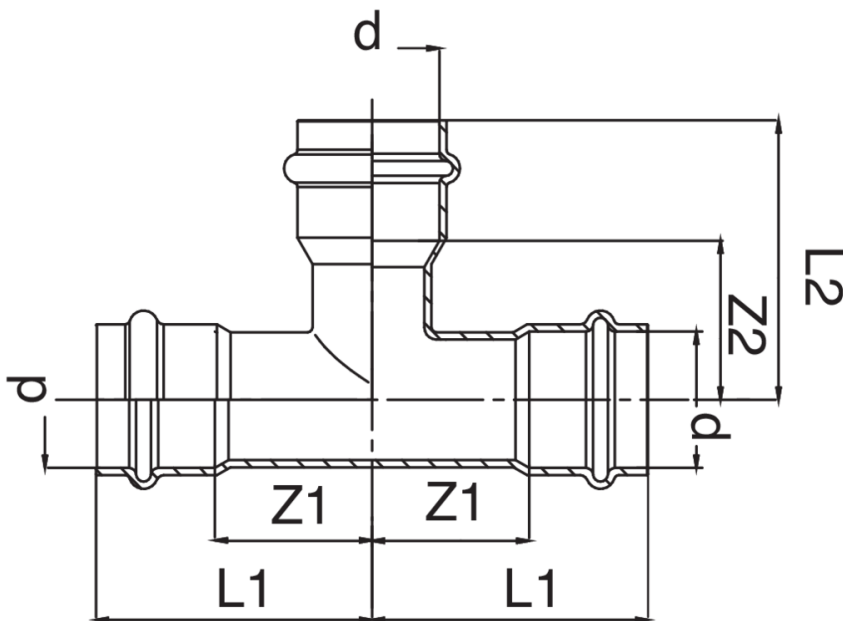

### Table

CODE	SIZE	DN	MASTER BOX	L1	L2	Z1	Z2
ZX0130015015015	15	15	40	42	44	20	22
ZX0130018018018	18	18	50	46	49	23	26
ZX0130022022022	22	22	30	49	53	25	29
ZX0130028028028	28	28	20	56	57	31	34
ZX0130035035035	35	35	15	66	63	42	37
ZX0130042042042	42	42	10	78	76	44	40
ZX0130054054054	54	54	5	82	92	42	51

Notes

The big-size, item AX0130, is available. See at page 108

Applications



DRINKING WATER



HEATING



HVAC



COMPRESSED AIR



FIREFIGHTING



MARINE



STEAM



SOLAR



INDUSTRIAL