

Manguito de paso H/H.

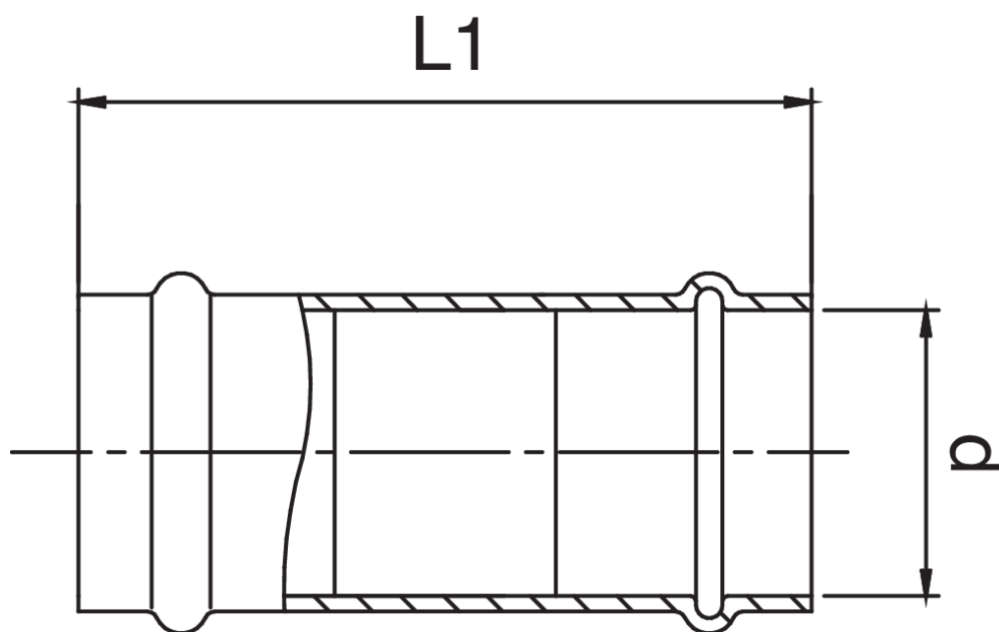

Especificaciones técnicas



D	BAG	MASTER BOX	CÓDIGO	L1
15	10	50	GX0271015015000	85
18	10	40	GX0271018018000	91
22	5	30	GX0271022022000	100
28	5	30	GX0271028028000	113
35	5	30	GX0271035035000	131
42	1	10	GX0271042042000	176
54	1	15	GX0271054054000	162

Aplicaciones



GAS



COMPRESSED
AIR



INDUSTRIAL